

COMPUTED TOMOGRAPHY

Prof. Yasser Mostafa Kadah

Computed Tomography

- X-ray based imaging method
- Main feature: sectional imaging rather than projection imaging

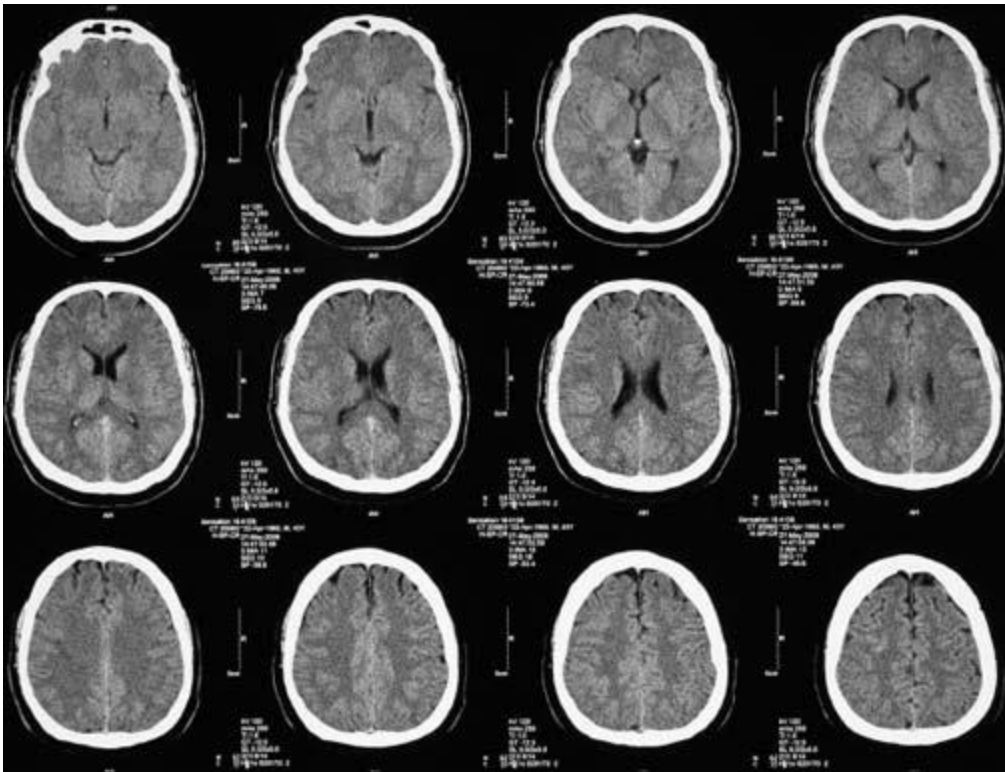

Computed Tomography Components

- **Gantry** with a central opening, into which the patient is moved during the examination.
- **X-ray tube**, the source of the X-rays that pass through the body situated in the gantry in the form of a series of projections;
- **Detector** array converts the projection values, in the form of radiation intensities, into electrical quantities. Usually, the whole detector array rotates synchronously with the X-ray tube around the test object
- **Table** allows the patient to be maneuvered easily into position

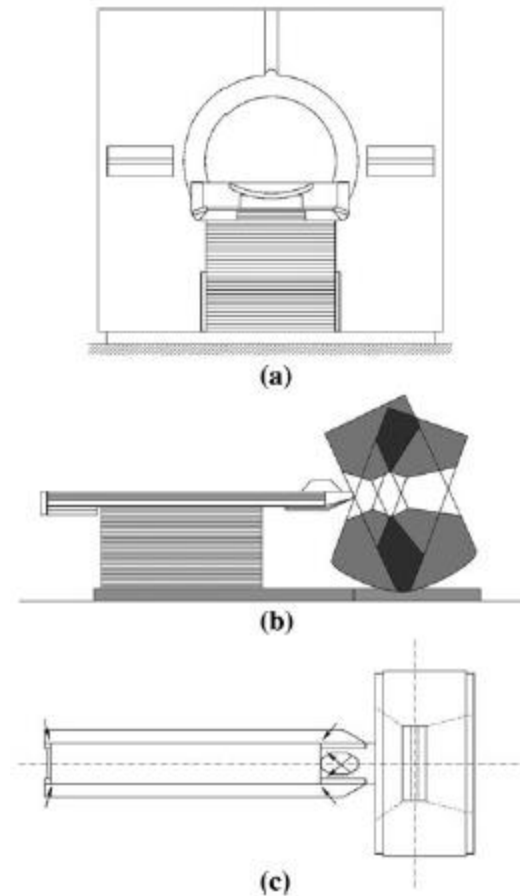

CT Scanner Design

- One of three basic tube-detector projection systems
- A projection system using a parallel beam of radiation
 - ▣ Parallel-beam system
- A system using a beam of radiation in the shape of a fan
 - ▣ Fan-beam system
- A system using a beam of radiation in the shape of a cone
 - ▣ Cone-beam system

First-Generation CT Scanners

- Pencil beam or translation/rotation single detector CT scanners
 - ▣ belong to the parallel-beam projection system
- Two components to the movement of the rigidly coupled tube-detector system
 - ▣ lateral movement to make a single projection
 - ▣ circular movement about the central opening in the gantry to gather all projections necessary to form the image
- Very slow (5 min/slice)

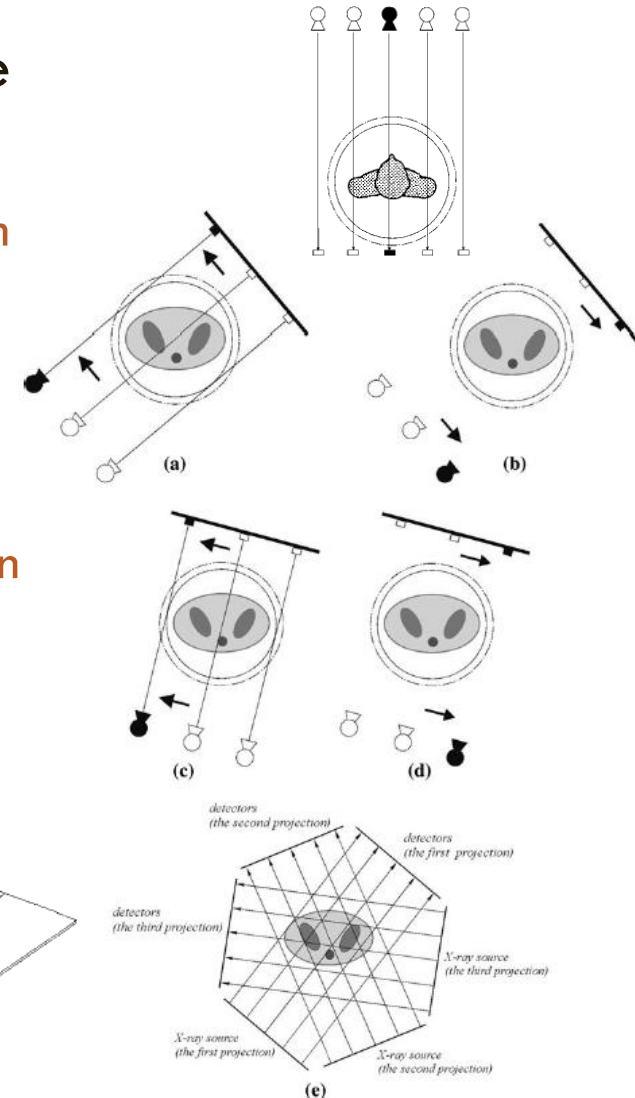
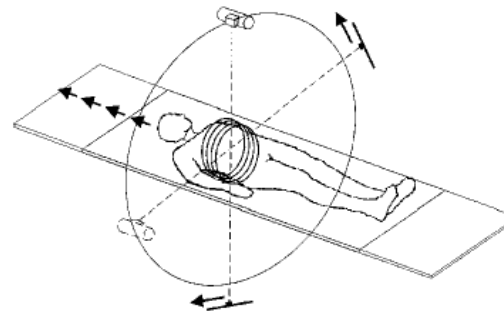

Second-Generation CT Scanners

- Partial fan beam or translation/rotation multiple detector scanners
- 3-52 detectors in the array
 - ▣ enable the projections to cover a larger area of the patient's body at any one time
 - ▣ results in reduction of number of projections needed to reconstruct an image
 - ▣ Faster!

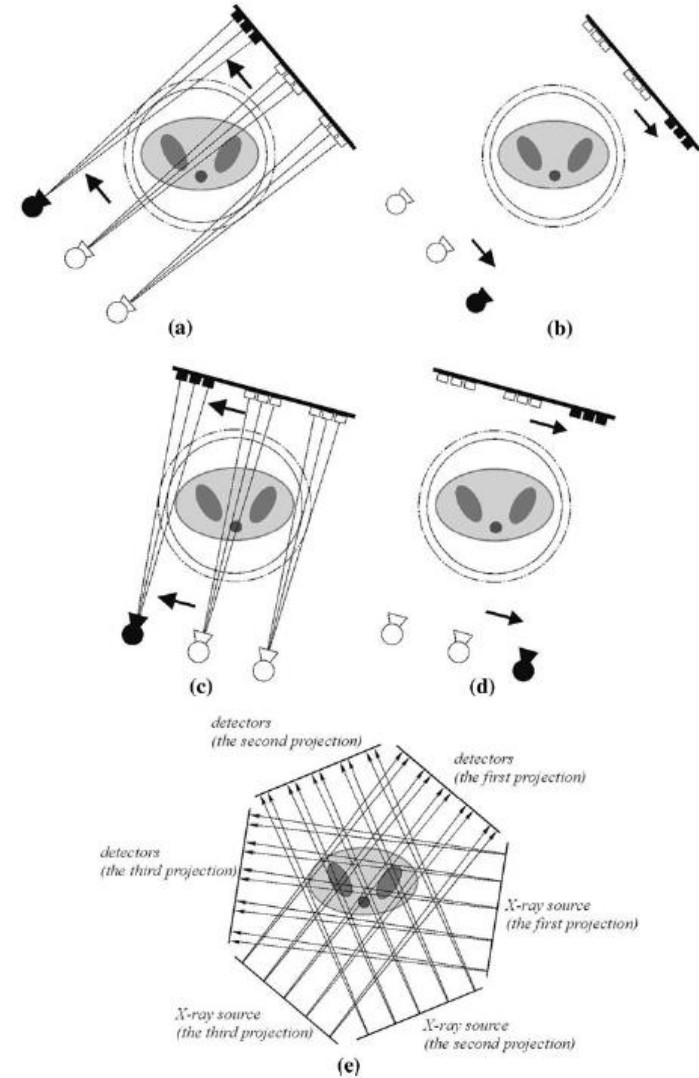

Third-Generation CT Scanners

- Elimination of lateral movement of tube-detector system
- Fan-beam or continuous rotation scanner
 - ▣ Fan beam of radiation (40-55 degrees) to encompass whole object
- Increase number of detectors in the array moving synchronously with rotating X-ray tube (up to 1,000 detectors)
- Much faster: 5 s/slice

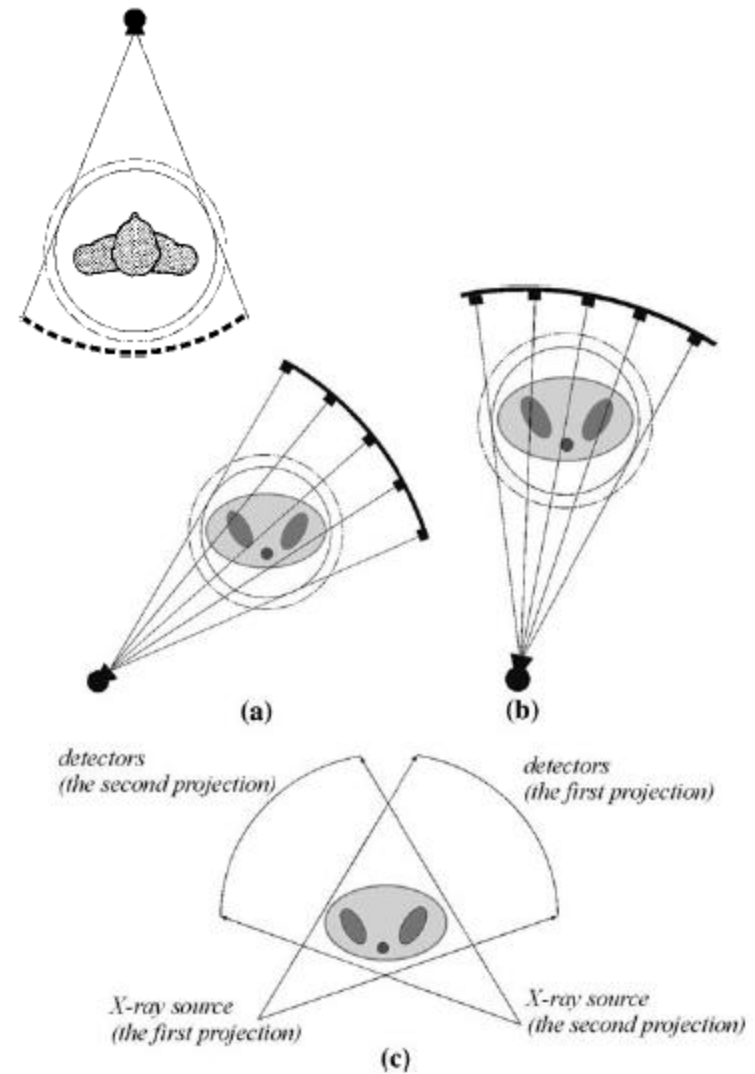

Fourth-Generation CT Scanners

- Differ only slightly from the third generation
 - ▣ Rotation of the detector array is eliminated by arranging it on a stationary ring
 - ▣ “Rotate-fixed” scanner

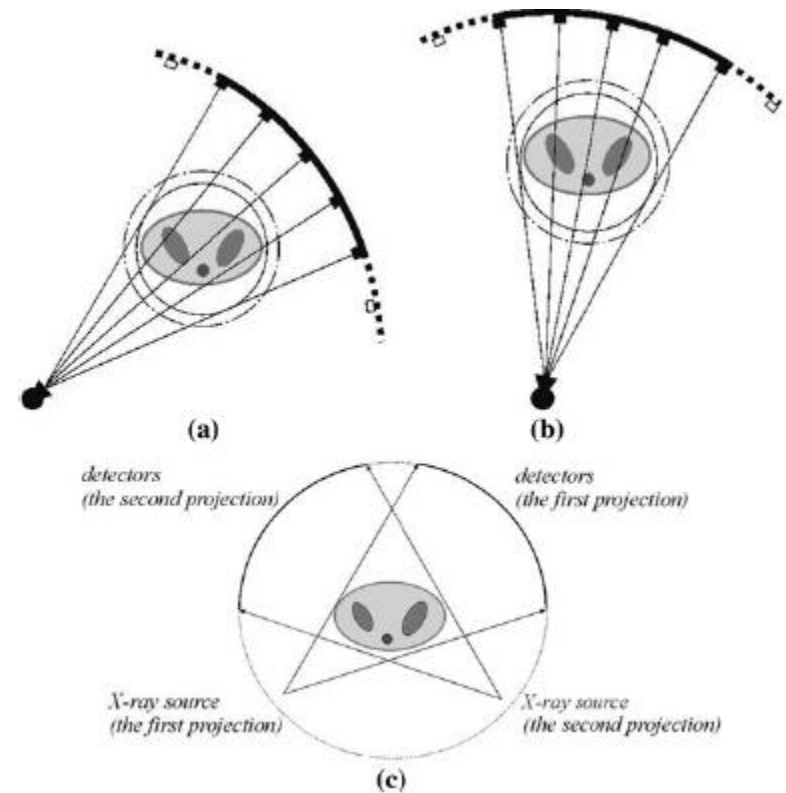
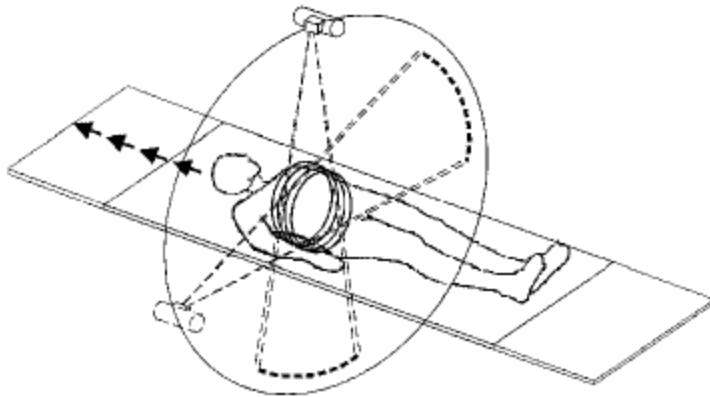

Spiral Scanners

- Fan beam scanning + table motion
- Single-slice spiral CT scanner (SSCT)
- Multi-slice spiral CT (MSCT)
 - ▣ 8-34 rows of detectors
- Cone beam spiral CT (CBCT)
 - ▣ possible to increase width of detector array to 16 or even 320 elements
 - ▣ Allowing simultaneous acquisition of up to 256 adjacent image slices
 - ▣ No collimation losses: less x-ray power
 - ▣ Faster, higher resolution scanning

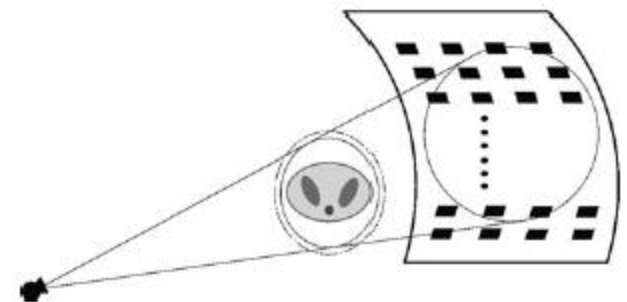
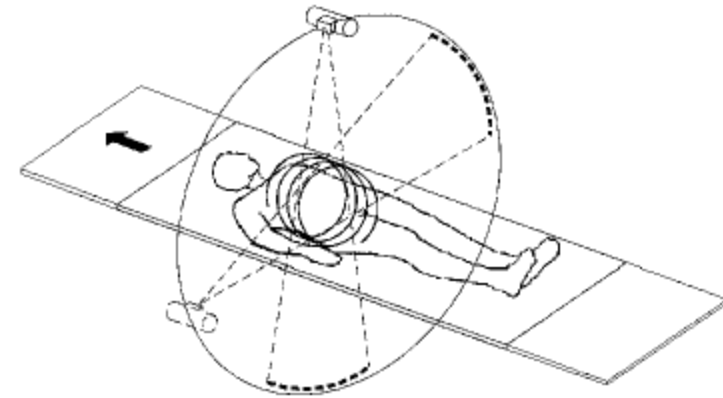

Hounsfield Units

- It is common practice in medical applications to use units on the Hounsfield scale: Hounsfield units (HU) .
 - ▣ Value usually varies in the range -1,000 (air) to 3,000 (bone), making it necessary to apply a so-called window (center C and width W).

$$\text{CT number} = 1000 \frac{(\mu - \mu_w)}{\mu_w}$$

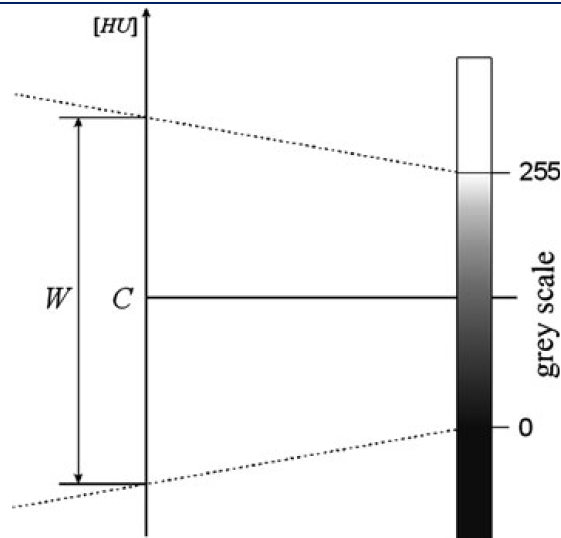
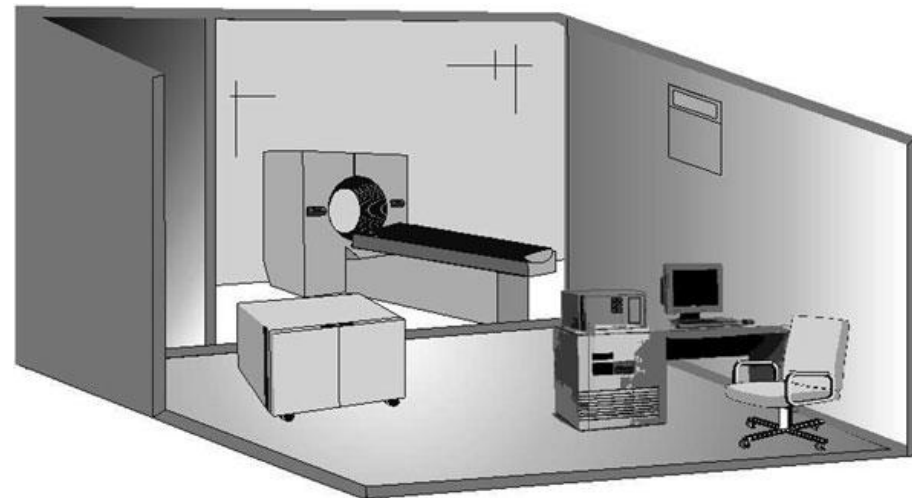
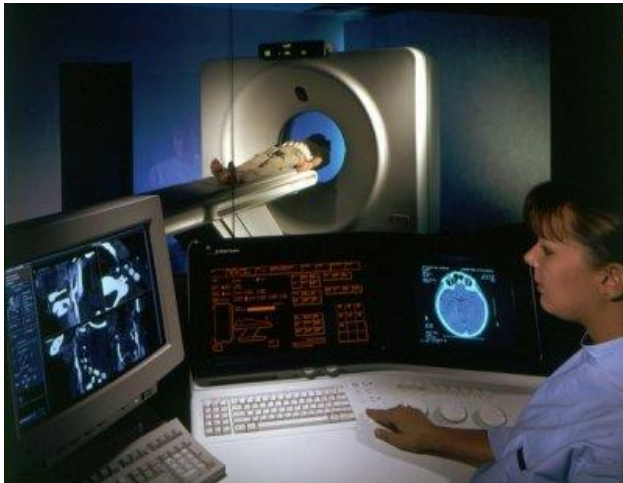

Fig. 3.41 The same slice viewed with different values of window parameters: the left image with the pulmonary window ($C = -600$, $W = 1,600$), the right image with the mediastinal window ($C = 50$, $W = 350$)

CT Installation

- CT room must meet several requirements
 - ▣ it must have floors with adequate load-carrying capacity
 - ▣ its walls must be constructed of X-ray absorbing material (this is usually a barium (Ba) plaster)
 - ▣ the floor should be lined with material that is both anti-slip and antistatic
- Separate rooms for CT scanner and radiographers;
 - ▣ Separated by special protective window-glass (containing lead, Pb)



CT Scanner Physical Elements

- A CT scanner consists of the following main elements
 - ▣ a data acquisition system that carries out the X-ray projections
 - ▣ a computer to reconstruct the images from the projections and to assist in the analysis of the reconstructed images
 - ▣ a variable power supply
 - ▣ a monitor to display the routine operation of the computer system and to act as an interactive interface in the diagnosis of reconstructed images
 - ▣ a documentation camera to produce an image on film similar to traditional X-ray images
 - ▣ other data archiving systems, such as tape or disk, collectively referred to as storage devices

Back-Projection Method

- Start from a projection value and back-project a ray of equal pixel values that would sum to the same value
- Back-projected ray is added to the estimated image and the process is repeated for all projection points at all angles
- With sufficient projection angles, structures can be somewhat restored

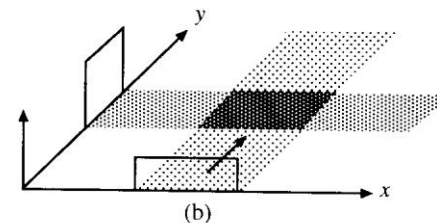
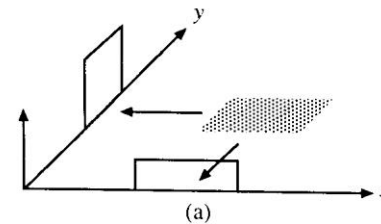
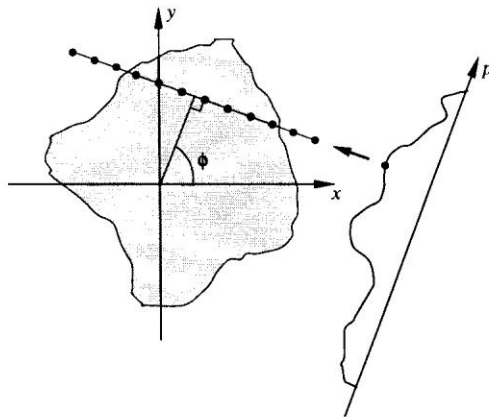

Back-Projection Example

True
Image

0	0	0
0	3	0
0	0	0

Projection Data

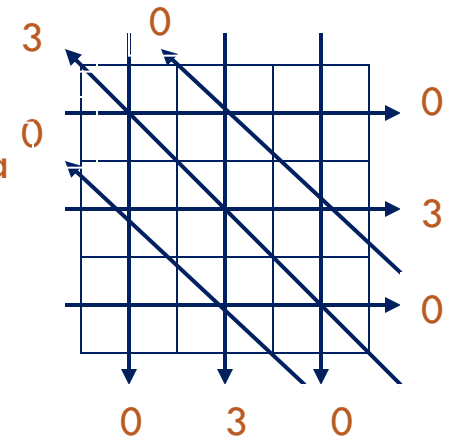

0	0	0
0	0	0
0	0	0

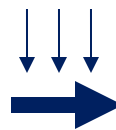

0	1	0
0	1	0
0	1	0



0	1	0
1	2	1
0	1	0



1	1	0
1	3	1
0	1	1

Initial
Solution



Iterate until sufficient accuracy is achieved



Algebraic Reconstruction Technique (ART)

- A low-complexity iterative solver to the algebraic reconstruction problem
- Starts with an initial estimate and tries to push the estimate closer to the true solution
 - ▣ Instead of back-projecting the average ray value, the error between the projection computed from current estimate and the true is used

$$Update = P_{\theta}(\rho) - \sum_{x,y} \alpha_{\rho}^{\theta}(x, y) \cdot \hat{I}(x, y)$$

ART Example

True
Image

1	2	3
4	5	6
7	8	9

Projection Data

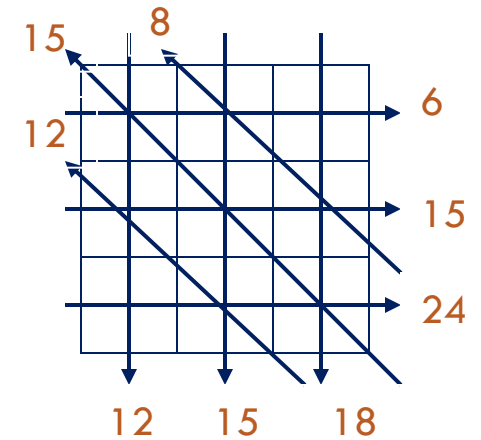

0	0	0
0	0	0
0	0	0

Initial
Solution

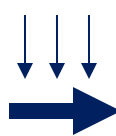

4	5	6
4	5	6
4	5	6



1	2	3
4	5	6
7	8	9

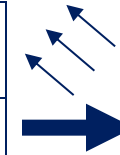

1	2	3
4	5	6
7	8	9

Iterate until sufficient accuracy is achieved



CT Image Artifacts

- Examples of CT artifacts: streak artifact (A), motion artifact (B), beam-hardening artifact (C), ring artifacts (D and E), and bloom artifact (F)

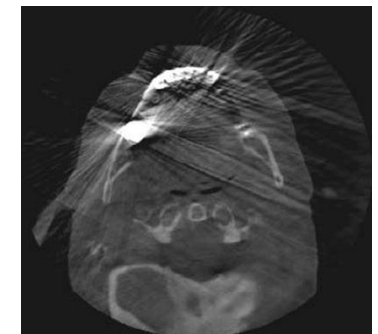
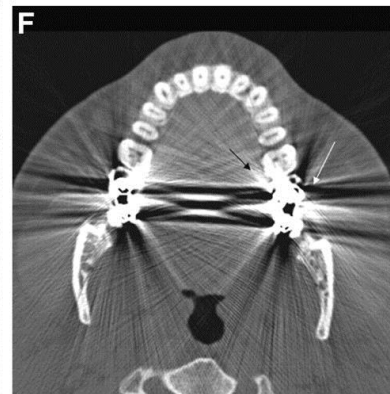
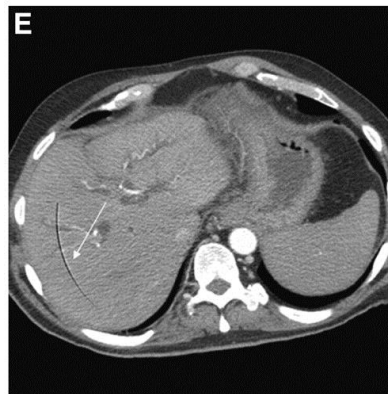
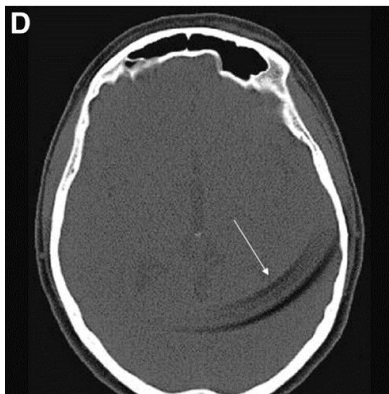
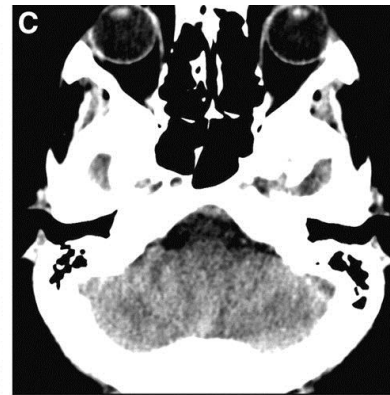
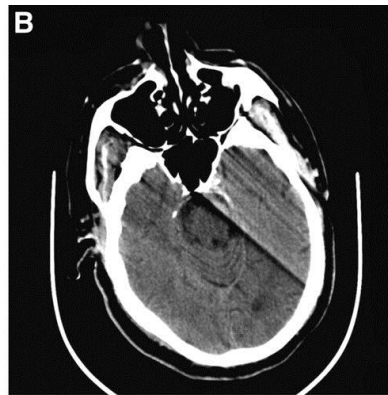
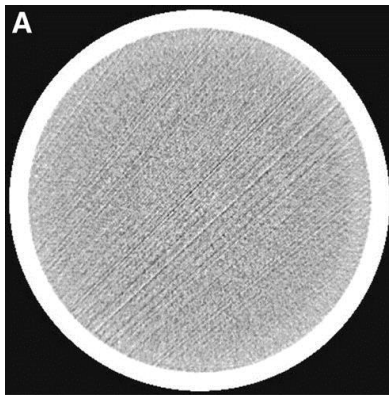

Evaluation of CT Devices

- The final CT image is produced as a result of a whole chain of processes and is affected by a range of factors
 - ▣ Technical parameters of the scanner
 - ▣ Type of projection system
 - ▣ Type of reconstruction algorithm applied
- Assessment of the physical and technical capabilities of CT scanners is made possible by the establishment of standardized, quantitative, comparative criteria.

Technical Parameters of CT Devices

- **Cycle Time:** The total time taken to scan and reconstruct the image
 - ▣ The smaller the cycle time, the greater the chance of avoiding the creation of artifacts caused by patient movement, including physiological movements such as the beating heart or chest movements while breathing

Technical Parameters of CT Devices

- **Spatial Resolution:** The minimum area in the image in which changes can be detected
 - ▣ This quantity is defined using the transfer function of the scanner $G(f_x, f_y)$ (called often the MTF, modulation transfer function)
 - ▣ MTF defines the frequency domain relationship between the original and the reconstructed image in the presence of noise, and determines the ability of the scanner to capture rapidly changing attenuation coefficients in the object
 - ▣ Spatial resolution is most often defined in terms of the cut-off frequency of the one dimensional transfer function, i.e. the value at which the function $MTF(f)$ drops to the 50, 10 or 2% level.

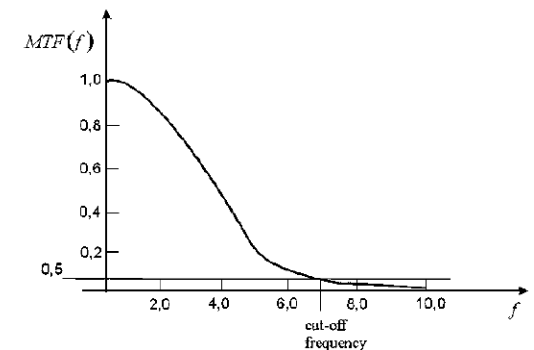

Technical Parameters of CT Devices

- **Low-Contrast Resolution (Contrast Detail):** The ability to detect small differences of attenuation coefficient in tissues.
 - ▣ It is defined as the ratio between the smallest detectable difference of attenuation coefficient (on the Hounsfield scale) and the average value within an object of a given size, for a specific radiation dose
 - This last factor is introduced because low-contrast resolution is proportional to the radiation dose
 - ▣ Current scanners have a resolution of between 0.3 and 0.4%. This can be increased by increasing the radiation dose or extending the scanning time

Technical Parameters of CT Devices

- **Uniformity:** A measure of the homogeneity of the image (or rather the heterogeneity)
 - ▣ This can be calculated from the average attenuation coefficients measured at selected areas of a uniform standard water phantom as:

$$\text{heterogeneity} = \frac{\mu^{\max}(x, y) - \mu^{\min}(x, y)}{\mu^{\max}(x, y) + \mu^{\min}(x, y)}$$

- ▣ where $\mu^{\max}(x, y)$ is the highest average attenuation coefficient from among all the selected areas of the phantom; $\mu^{\min}(x, y)$ is the smallest average attenuation coefficient from among all the selected areas of the phantom

Technical Parameters of CT Devices

- **Linearity (Sensitometry):** defines the relationship between the attenuation coefficients measured at the average energy of the scanner and the values assigned to them on the Hounsfield scale for all types of tissue, using the formula

$$\text{linearity} = \sqrt{\frac{1}{I} \sum_{i=1}^I (\mu_i - \mu_i^{\text{av}})^2}$$

- where μ_i is the attenuation coefficient assigned to a given tissue, on the Hounsfield scale; μ_i^{av} is the attenuation coefficient measured at the average energy of the scanner; I is the number of the tissue under consideration

Technical Parameters of CT Devices

- **Slice Thickness:** The nominal thickness of the image cross-section
 - ▣ This is often determined using the value of the full width at half maximum (FWHM) of the scanner, which is defined on the basis of the sensitivity function of the scanner (Example of simplified sensitivity function is shown)
 - ▣ The slice thickness is the distance between the two points on the graph of the sensitivity function, which have values equal to half the maximum value.
 - ▣ A typical value for this parameter would be in the range 0.4–10 mm

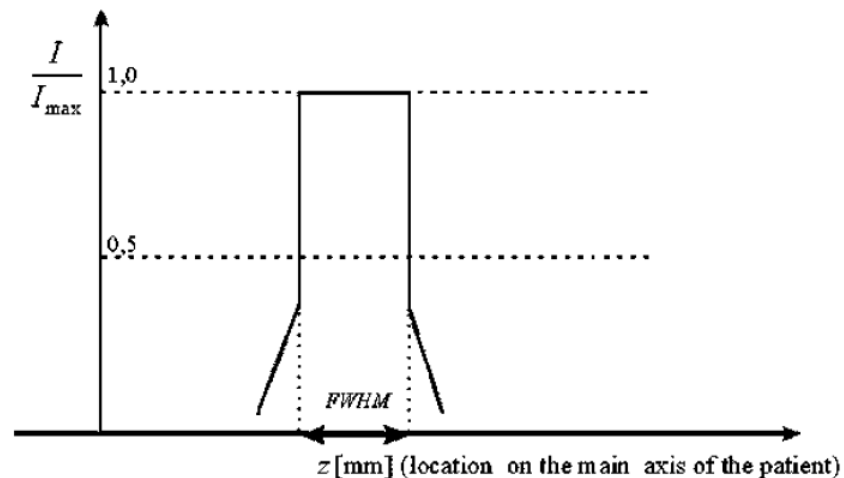

Technical Parameters of CT Devices

- **Computed Tomography Dose Index (CTDI):** This index is measured in milligrays (mGy) and defines what dose a patient absorbs when scanned by a particular CT apparatus

- CTDI is determined by:

$$\text{CTDI} = \frac{1}{|z_2 - z_1|} \int_{z_1}^{z_2} \text{Dose}(z) dz,$$

- where $\text{Dose}(z)$ is the distribution along the z-axis of the dose absorbed by a phantom during the test; z_1, z_2 are the start and endpoints on the z-axis of the measurements made by the dosimeter
- Total dose absorbed by the patient should not exceed permissible levels and consequently, much of the efforts of manufacturers of tomographic equipment are currently directed towards minimizing this dose.

Technical Parameters of CT Devices

- **Pitch:** The ratio between the displacement of the table with the patient on it and the thickness of the scanned layer for one revolution of the scanner
 - ▣ This factor is only relevant to spiral scan systems

$$\text{pitch} = \frac{\lambda}{SW},$$

- ▣ where λ is the relative travel of the spiral described by the tube as it moves around the test object in (mm/rad); SW is the nominal thickness of the layer in (mm)

Quality Control Phantoms

- ATS Phantom proposed by American Association of Physicists in Medicine (AAPM)
 - ▣ Designed to test low-contrast resolution
 - ▣ Situated inside the Plexiglas housing of this phantom are rows of circular inserts with diameters that change from row to row
 - ▣ These inserts have adjustable attenuation coefficient values, expressed on the Hounsfield scale. The whole of the inside of the phantom is filled with water

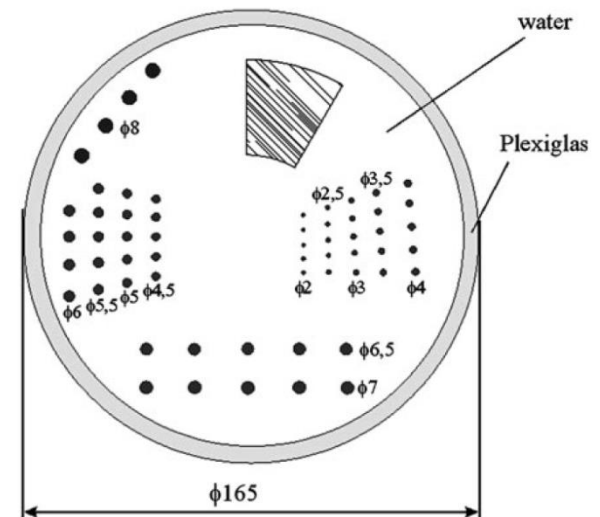

Quality Control Phantoms

- Moström's Phantom
 - ▣ Used to measure the Linearity (sensitometry) or homogeneity of the image
 - ▣ In the example of the phantom illustrated, the parameter $l = 5$

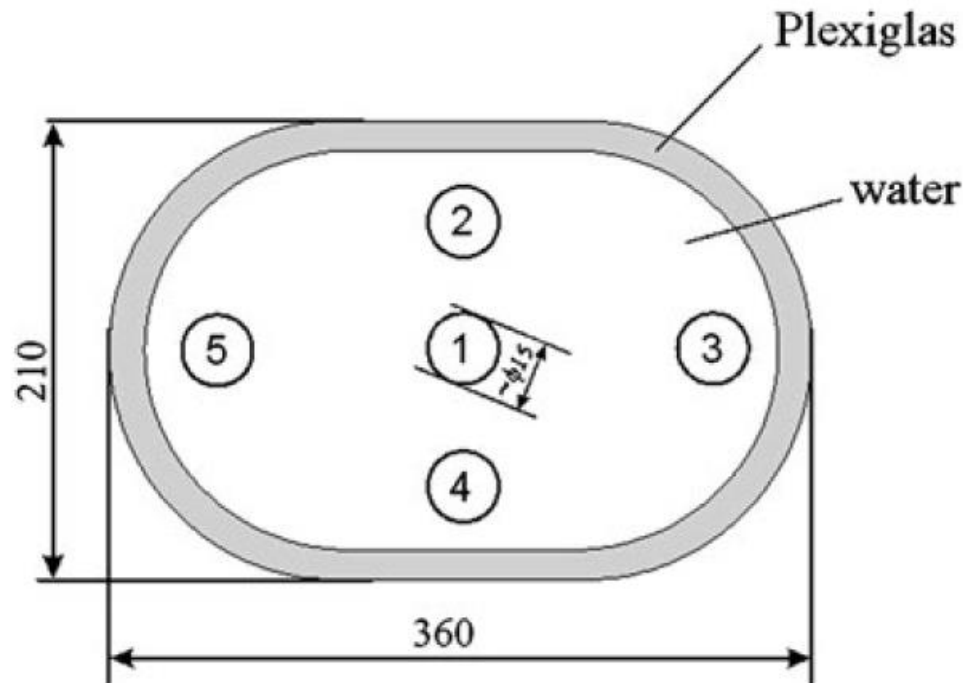

Quality Control Phantoms

□ Low-contrast Resolution Phantom

- The earliest design of phantom used to measure low-contrast resolution
- The metal rods, shown immersed in water in the diagram, are arranged in rows, where both the diameter d_i and the distance between the rods $2d_i$ decrease as the index i of the row increases
- The low-contrast resolution of the scanner is determined by the smallest diameter of rod, which is visible as a distinct element in the reconstructed image

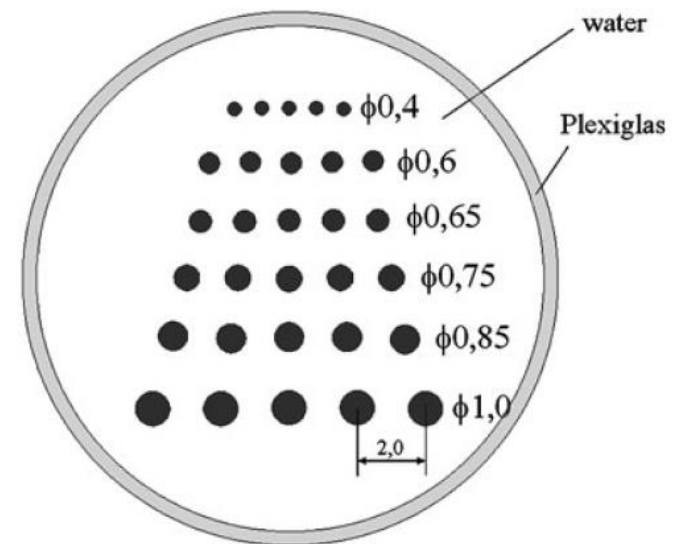

Quality Control Phantoms

□ Spatial Resolution Phantom

- Spatial resolution (units: lp/cm) is determined by the use of a phantom to measure the point spread function
- In this phantom, a length of stainless steel wire is placed perpendicular to the test cross-section
- The MTF, which directly determines the resolution of the scanner, can be calculated using the Fourier transform of the reconstructed image. Because the diameter of the wire is small in relation to the size of the pixels, it can be neglected in the calculation.

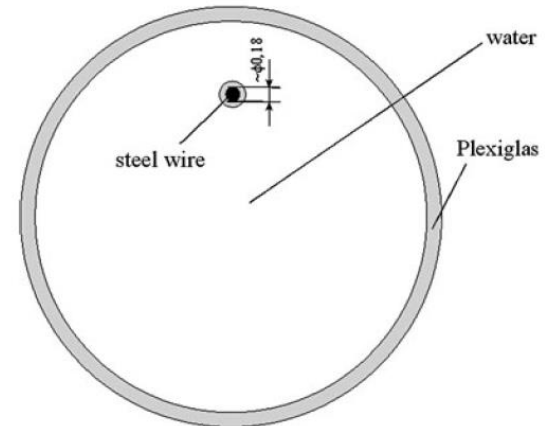

Quality Control Phantoms

□ CT Linearity Phantom

- Assess the linearity of the tomographic image (parameter $l = 5$)
- The five materials used here are selected according to the Hounsfield number assigned to them chosen to cover the widest possible range of the scale
- By drawing a graph of the relationship between the Hounsfield numbers assigned to these materials and their attenuation coefficients measured by the scanner (at the average radiation energy), we can establish the nonlinearity parameter based on its equation

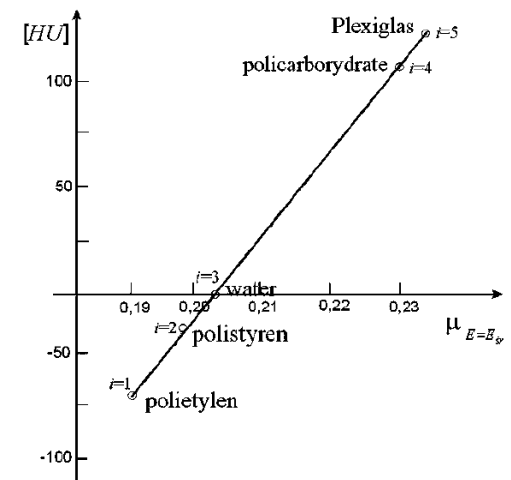
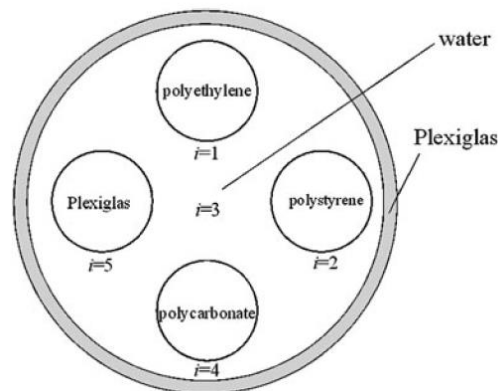

Quality Control Phantoms

□ Slice Thickness Phantom

- ▣ This phantom has two aluminum strips of thickness $b = 0.6$ mm inclined to the reconstruction plane at a fixed angle ϕ (30 or 45 degrees)

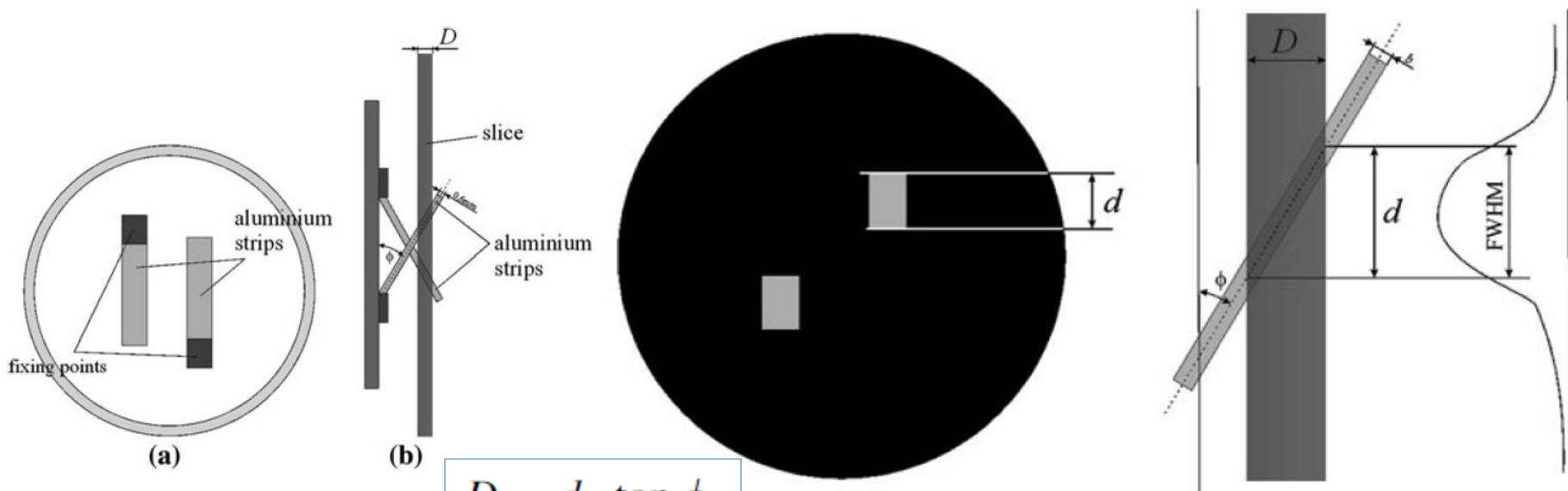

$$D = d \cdot \tan \phi.$$

$$D_{\min} = \frac{b}{\cos \phi}.$$

Quality Control Phantoms

□ Phantom Simulating a Skull Bone

- Filters are often used in reconstruction algorithms to compensate for the distortions to the image at boundary between skull and brain.
- Use of phantoms described before would cause these filters to have an adverse effect on reconstructed image in absence of skull bone
- For that reason, a Teflon rim, as shown is usually fitted to one of the phantoms described above to simulate the skull bone

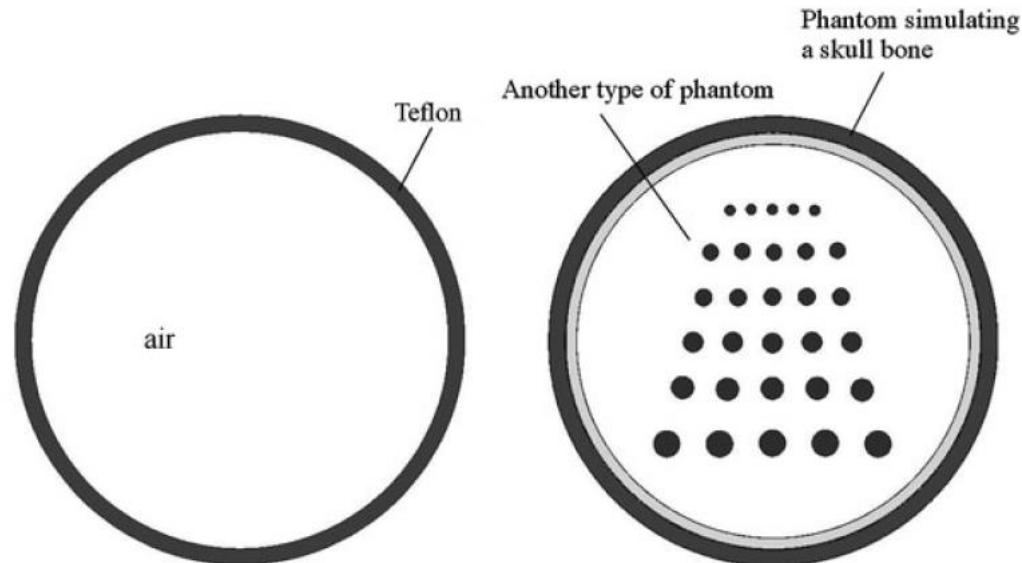

Start-Up and Test Procedures

- To ensure reliable operation of CT scanner throughout the whole of its working life, it is important that all manufacturer's recommended procedures for startup and testing are followed
- After sliding the table out of the scanner's gantry (Feed Out), image quality is tested (Test Image), but without the emission of radiation to confirm the correct operation of the imaging system
- Next step is to prepare x-ray tube for operation by heating it up (Warm Up).
- Next step (Calibration) takes place in the absence of any radiation-absorbing material in the gantry of scanner.
 - ▣ Measurements made at this time form the basis of the corrections that must be made to the projections obtained during the routine operation of the scanner

Start-Up and Test Procedures

- After calibration, procedures testing operation of CT scanner are carried out (Quality) and can be divided into two types:
 - ▣ Qualitative tests, performed each day or weekly
 - ▣ Stability tests, performed each month
 - ▣ Annual tests.
- Set of **daily/weekly** tests (performed by **technicians**) to check the quality of the reconstructed image might include:
 - ▣ Test to measure the homogeneity of the image
 - ▣ Test of the point spread function
 - ▣ Check of the X-ray tube voltage

Start-Up and Test Procedures

- A battery of tests performed by **service personnel or technicians** on a **monthly** basis might consist of measuring the following items:
 - ▣ Spatial resolution
 - ▣ Positioning accuracy
 - ▣ Linearity
 - ▣ Slice thickness
- **Annual** tests might be a combination of the following examinations (performed by **physicists**):
 - ▣ Daily/weekly tests
 - ▣ Index accuracy and table positioning test
 - ▣ Contrast scale test
 - ▣ Distance accuracy test
 - ▣ Patient dose

Start-Up and Test Procedures

- In an emergency, if the time needed to perform the entire start-up procedure could affect the life or health of the patient, a fast start-up procedure (Quickstart) can be carried out, which excludes all the points selected in the start-up window
- Appropriate tests should also be carried out on the scanner after the installation of the equipment and after any routine maintenance or servicing
 - ▣ Application software installed on the scanner's computer enables the results of the tests to be saved, so creating a history of the device for purposes of comparison.

Covered Material

- Parts of chapters 3 and 9 of Cierniak textbook
- Parts of chapter 15 of Hendee and Ritenour textbook